

**Alarm wiring**  
- default wiring is to disable alarm by putting a jumper on J4

**BRAID TOGETHER**

**TWIST TOGETHER**

**TWIST TOGETHER**

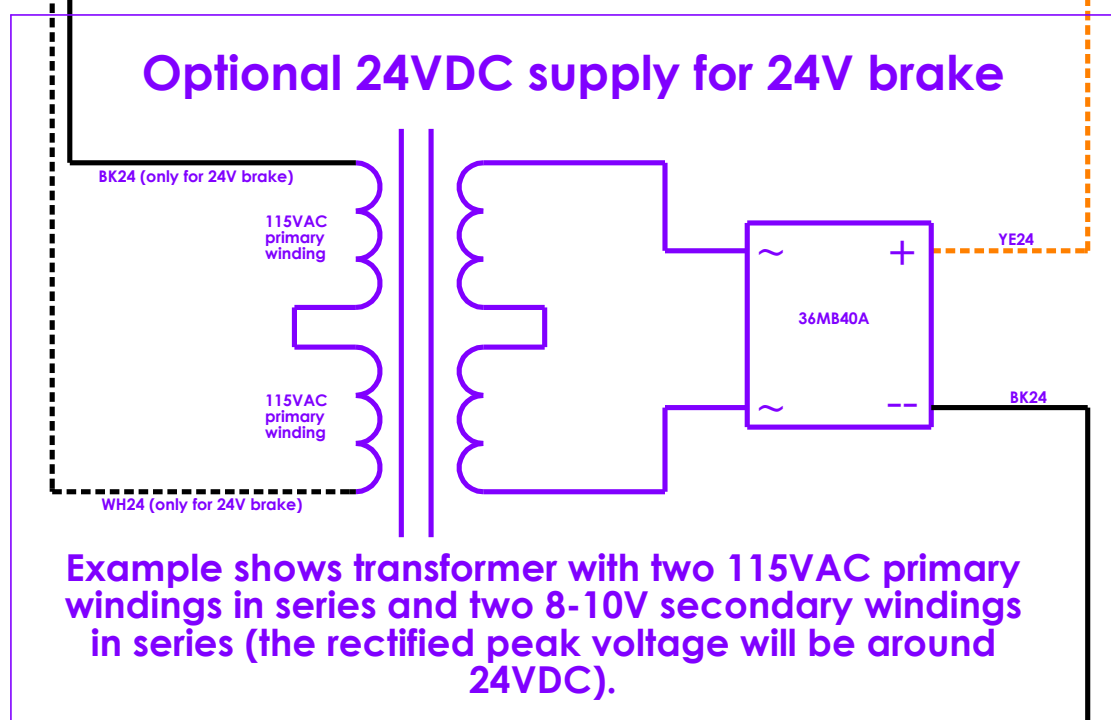
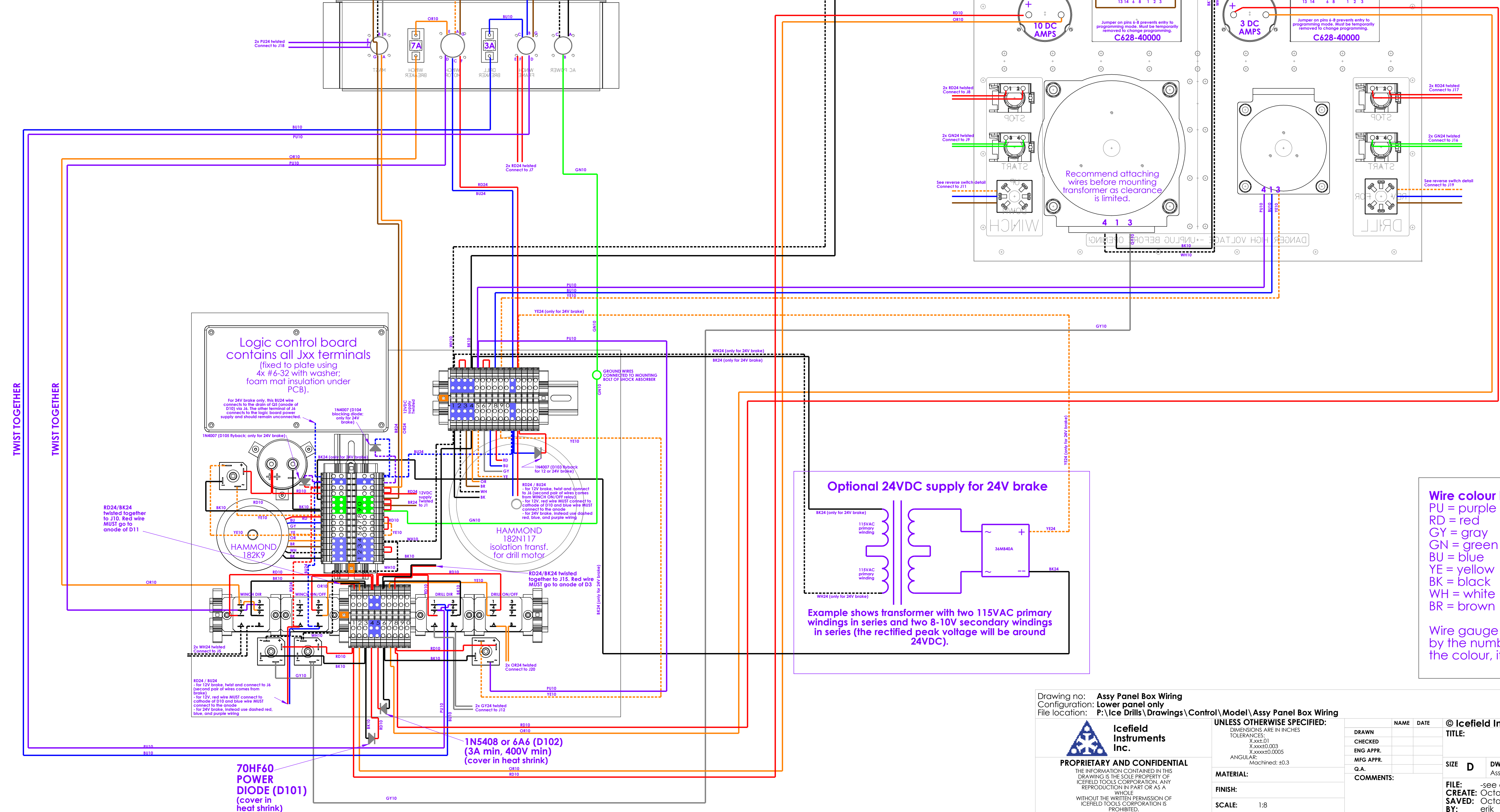

**Wire colour legend**

- PU = purple
- RD = red
- GY = gray
- GN = green
- BU = blue
- YE = yellow
- BK = black
- WH = white
- BR = brown

Wire gauge is indicated by the number following the colour, if applicable.

Drawing no: **Assy Panel Box Wiring**  
 Configuration: **Lower panel only**  
 File location: **P:\Ice Drills\Drawings\Control\Model\Assy Panel Box Wiring**

**Icefield Instruments Inc.**  
 PROPRIETARY AND CONFIDENTIAL

UNLESS OTHERWISE SPECIFIED:  
 DIMENSIONS ARE IN INCHES  
 TOLERANCES:  
 X.xxx.01  
 X.xxx±0.003  
 X.xxx±0.0005  
 ANGULAR:  
 Machined: ±0.3

**MATERIAL:**  
**FINISH:**  
**SCALE:** 1:8

NAME	DATE
DRAWN	
CHECKED	
ENG APPR.	
MFG APPR.	
Q.A.	
COMMENTS:	

© Icefield Instruments Inc.  
**TITLE:**  
 SHEET 1 OF 2

SIZE **D** DWG. NO. **Assy Panel Box Wiring** REV  
 FILE: -see above-  
 CREATE: October-06-12 02:36:09  
 SAVED: October-21-12 18:51:54  
 BY: erik

**Reverse switch detail**

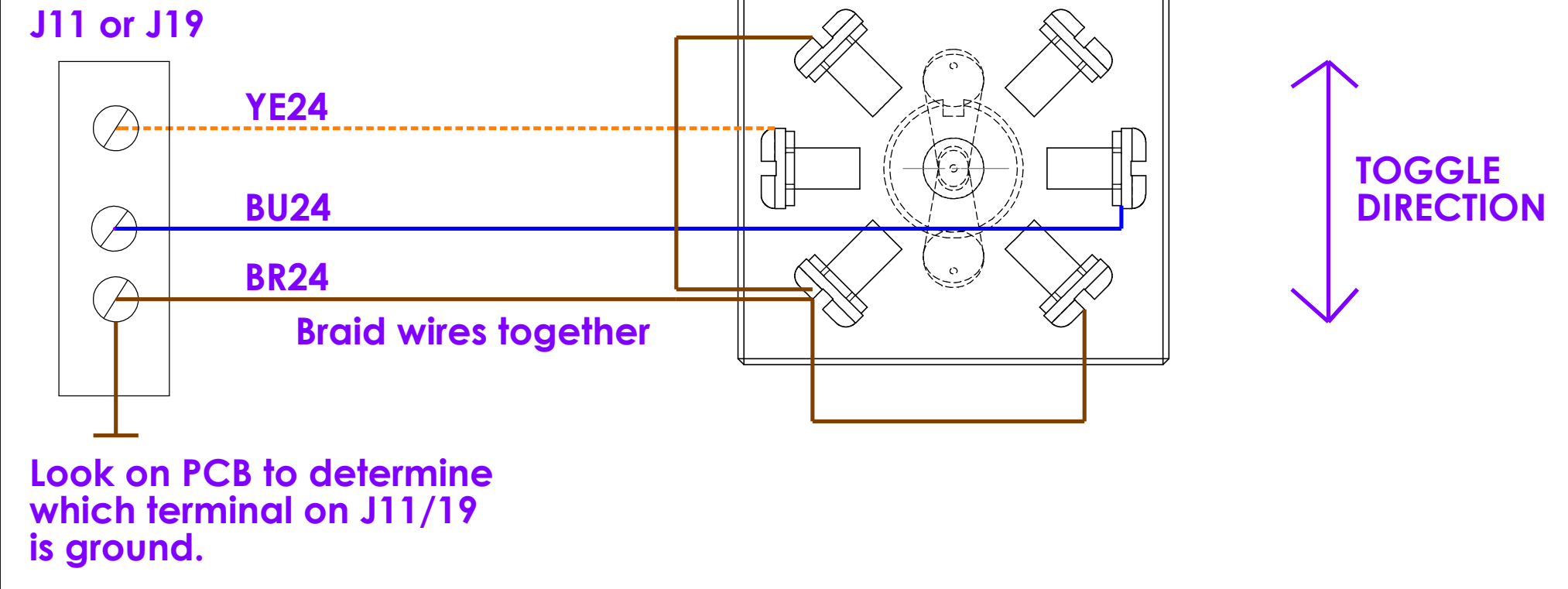

**CONTROL PANEL WIRING INSTRUCTIONS**

- the control panel is subject to extreme and prolonged vibration and shaking during transport, as well as corrosive (salty) air, so ensuring high quality wiring and connections is critical to reliable operation.

**WIRE ROUTING:**

- all wires should be routed neatly along the wiring corridors (T-strips and edges of the interior wiring panel).
- the interior wiring panel is shock-mounted and will move up to 1" (2.5cm) laterally. Therefore, wires between the military connectors and the wiring panel **MUST** have appropriate slack or the wires will get ripped apart.
- there should be one bundle of wires bridging between the bottom of the control panel and the interior wiring panel. This bundle should form a sweeping "S" curve so that the wires are not stressed when the control panel is opened and closed. The bundle may be secured to the U-bolt at the back of the panel.

**MOUNTING COMPONENTS:**

- all metal mounting fasteners located on non-plastic parts should be secured with blue Loctite.
- all fasteners located on plastic parts (e.g., analogue meters) should be secured with nail polish. Loctite will attack and damage plastic!
- clip-type mounting systems (e.g., counters/tachometers) must be reinforced using RTV silicone (with surfaces pre-cleaned with propanol). Otherwise the clips will pop and the parts will fall loose.
- do NOT use Loctite or nail polish on electrical terminals (these materials are not conductive). If appropriate, use a lock washer.

**STRIPPING WIRE:**

- all wires should be stripped using thermal strippers to ensure that there are no nicks in the wire strands.

**CRIMP TERMINALS:**

- for RING and TAB crimp terminals (never use SPADE terminals as they will fall out if the fastener loosens), the wire must be crimped and **SOLDERED** into the terminal.

**BARE ENDS:**

- for bare ends of wires (e.g. on the terminal strips of the counters/tachometers, and on the DIN-rail terminal blocks), the wires should be stripped and tinned before connection. Use firm torque when tightening terminal connections.

**DIN TERMINALS:**

When connecting to DIN terminals, take care that the wire extends far enough into the block to be caught by the clamp. This is particularly the case for the lower level (see picture below). All four terminals on a given block are connected together internally. In addition, the ground blocks (green/yellow) have a connection to the rail (safety ground).

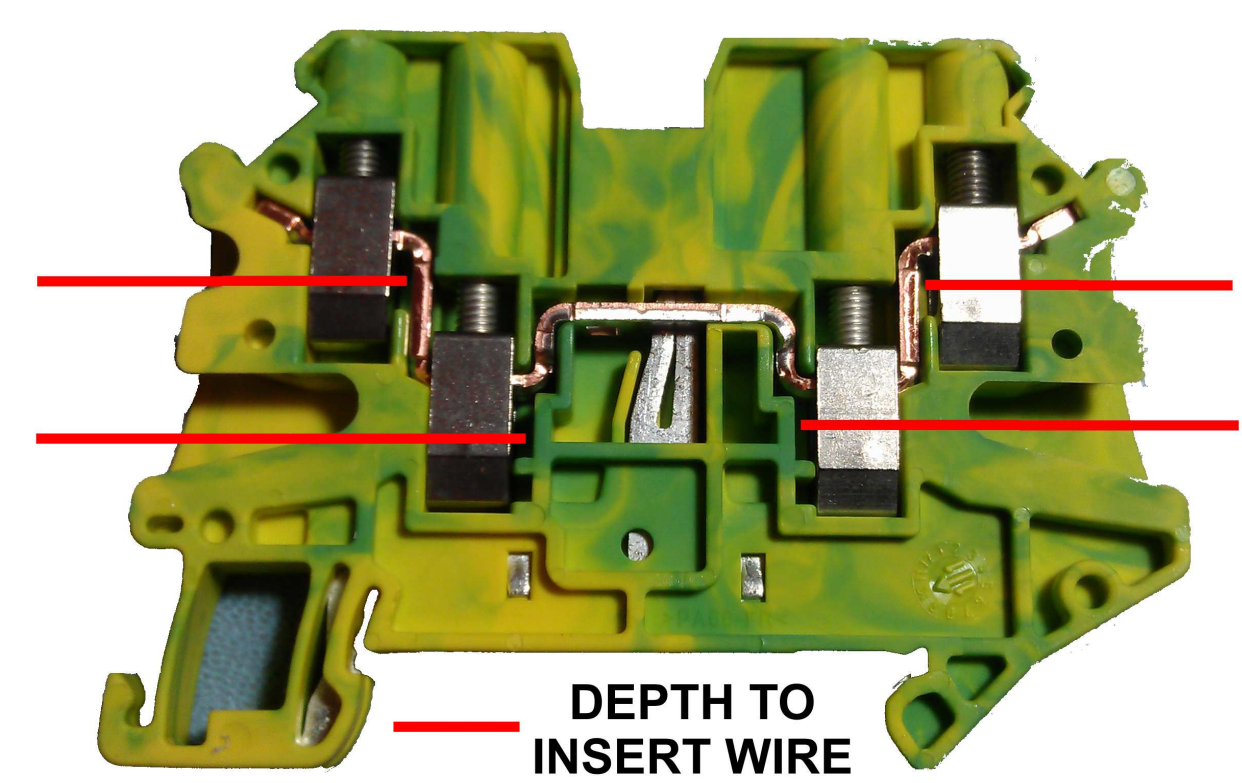

Drawing no: **Assy Panel Box Wiring**  
 Configuration: **Default**  
 File location: **P:\Ice Drills\Drawings\Control\Model\Assy Panel Box Wiring**

**Icefield Instruments Inc.**  
 PROPRIETARY AND CONFIDENTIAL  
 THE INFORMATION CONTAINED IN THIS DRAWING IS THE SOLE PROPERTY OF ICEFIELD TOOLS CORPORATION. ANY REPRODUCTION IN PART OR AS A WHOLE WITHOUT THE WRITTEN PERMISSION OF ICEFIELD TOOLS CORPORATION IS PROHIBITED.

**UNLESS OTHERWISE SPECIFIED:**  
 DIMENSIONS ARE IN INCHES  
 TOLERANCES:  
 X.xxx±.01  
 X.xxx±0.003  
 X.xxxxx±0.0005  
 ANGULAR:  
 Machined: ±0.3

DRAWN	NAME	DATE	© Icefield Instruments Inc.
CHECKED			TITLE:
ENG APPR.			
MFG APPR.			
Q.A.			
COMMENTS:			

SIZE **D** DWG. NO. **Assy Panel Box Wiring** SHEET 2 OF 2  
 REV

FILE: -see above-  
 CREATE: October-06-12 02:36:09  
 SAVED: October-21-12 18:51:54  
 BY: erik